

Gotthard Knödseder  
Bohrtechnik



 **COMACCHIO**  
DRILLING HI-TECH

**MC 12**

S/N: 2548

BAUJAHR: 2016



## GERÄTEDATENBLATT

**GOTTHARD KNÖDLSEDER HAMMERWERK GMBH**

Industriestraße 20

 94051 Hauzenberg

 +49 85 86 / 96 78 0

Fax +49 85 86 / 96 78 25

 [info@knoedseder.com](mailto:info@knoedseder.com)

**GOTTHARD KNÖDLSEDER BOHRTECHNIK GMBH**

Kenzianweg 8

 4780 Schärding

 +43 77 12 / 49 94 6250

Fax +43 77 12 / 49 94 6251

 [info@knoedseder.com](mailto:info@knoedseder.com)



## Transportdaten

Gesamtgewicht [kg]:	12.000
Länge [mm]:	7.085
Breite [mm]:	2.100
Höhe [mm]:	3.156
Bodendruck [kg/cm <sup>2</sup> ]:	1,28

## Motor

Type:	Diesel / DEUTZ TCD 4.1
Leistung [kW]:	115
Abgasstufe:	STEP 4 / Tier 4i DPF
Dieseltank-Inhalt [L]:	150
Schallpegel [dB (A)]:	107
Hydrauliköltank [L]:	390

## Bohrantrieb

**Drehantrieb** Einzelkopf

**Hydraulikhammer** Eurodrill HD 4010

max. Drehmoment [daNm]:	Gang 1 / 2	1.100 / 550
max. Drehzahl [U/min]:	Gang 1 / 2	43 / 86
Einzel Schlagenergie [Nm]		500
Schlagfrequenz [min-1]		2.400

## Lafette

Vorschubkraft [daN]:	6.000
Rückzugskraft [daN]:	6.000
Gesamtlänge [mm]:	4.260
Nettovorschub [mm]:	2.540

## Mastverlängerung 1.500 mm

Gesamtlänge 1 [mm]:	5.760
Nettovorschub 1[mm]:	4.040

## Klemm- / Brechvorrichtung

Klemmbereich [mm]:	38 - 320
Klemmkraft [daN]:	23.000

## Sonstige Ausstattung

### Hochdruckwaschgerät

max. Fördermenge [L/min]:	20
max. Druck [bar]:	150
Zubehör:	Schlauchaufroller mit 15m Schlauch, Waschanze mit Zubehör

### Transportposition

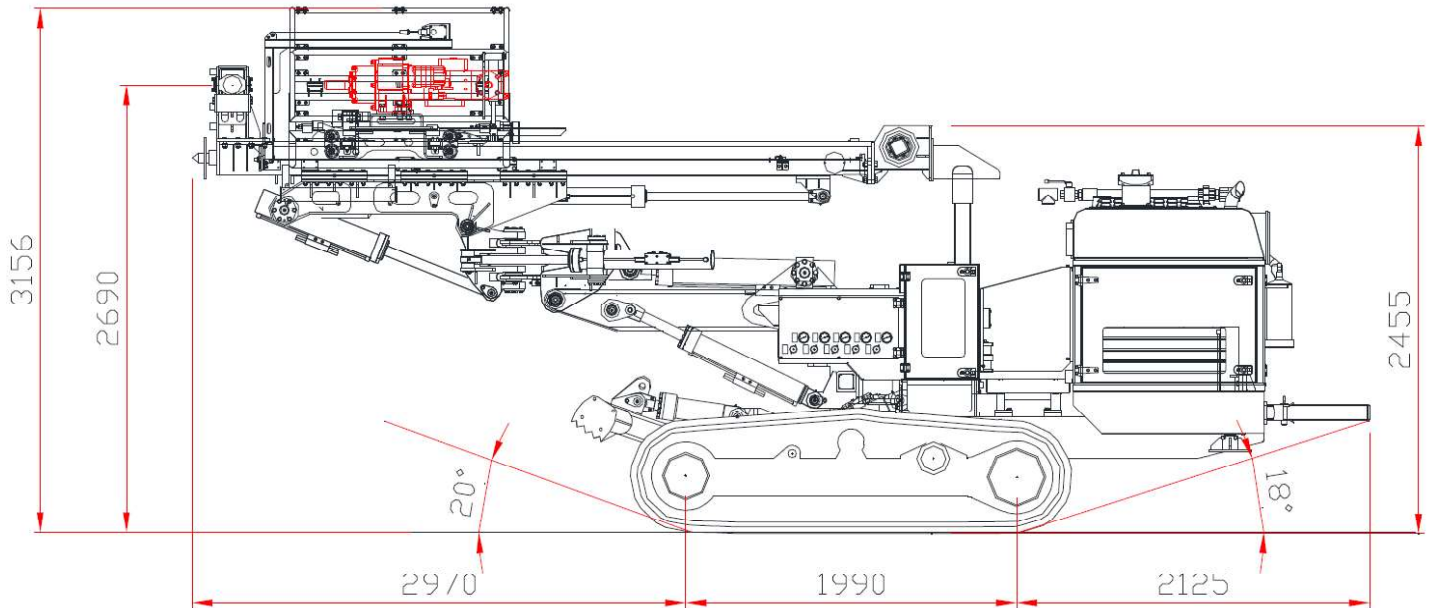

### Mit Mast in vertikaler Position

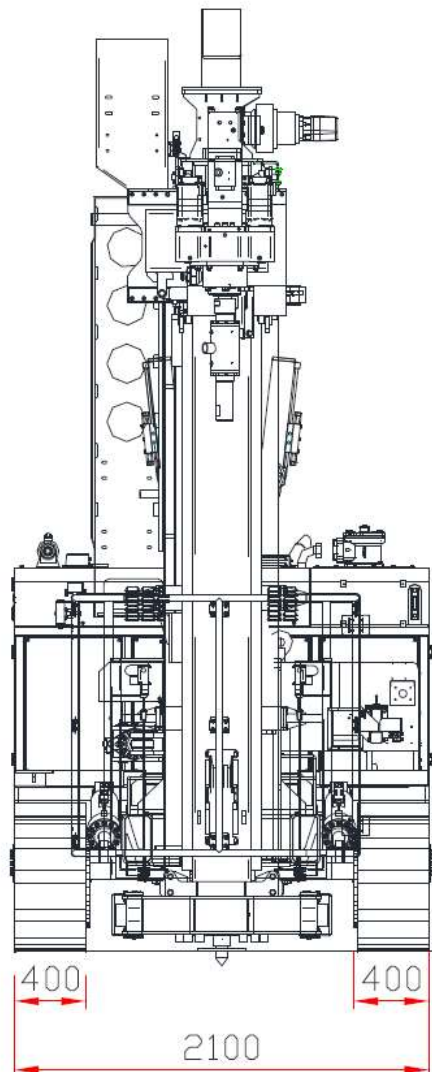

Mit Mast in vertikaler Position

